

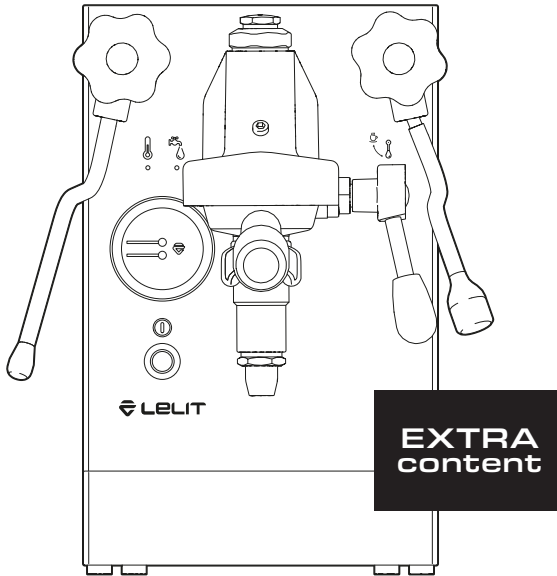

## Extended guide



*	PL62X	PL62X-EU	PL62X-AUS	PL62X-AS	PL62X-100	PL62X-120
	230 V 50 Hz	230 V 50 Hz	240 V 50 Hz	220 V 50/60 Hz	100 V 50/60 Hz	120 V 60 Hz
	E+F	E+F	I	G	B	B



2

## THANK YOU FOR CHOOSING A LELIT PRODUCT

Register your product on  
[care.lelit.com](https://care.lelit.com)

Download the complete guide  
to get the most of your coffee machine **PL62X\***  
and visit our LELIT YouTube channel.



**Save the box and all  
the packing material!**

LELIT has studied the external and internal packing  
of your coffee machine to help you re-use it in case  
of maintenance or repair need.

# Index

---

1. Main specifications	EXTRA	4
2. Product overview		6
3. Factory settings		6
4. Equipment box		7
5. Packing		8
6. First start-up		8
7. How to install the water softener filter		9
8. Espresso and coffee		10
9. Steam and hot water		11
10. Stand-by mode	EXTRA	12
11. Functioning modes	EXTRA	13
12. The art of espresso coffee	EXTRA	16
13. Limescale prevention		19
14. Daily cleaning		19
15. Weekly cleaning		20
16. Annual cleaning		21
17. Pilot lights and states		22
18. Most common problems	EXTRA	23
19. Warranty terms		26

# 1. Main specifications **EXTRA**

4



## User Friendly

This machine allows anyone to make an espresso as good as it tastes at a café.



## Brushed stainless steel

Its brushed stainless steel appliance body and its details make it a wonderful piece of design even when the machine is switched off. Thanks to the brewing group, this machine is the perfect union between coffee culture and innovation.



## Stainless steel boiler

The new stainless-steel boiler AISI316L is a detail aimed at improving the final result: an espresso that keeps its taste and aroma intact through each single bean from the start to the very end.



## Coffee Slide

A dispensing spout that can be used for both one or two cups and that allows the user to see the coffee cream on its way towards the cup.



## Energy saving

When the machine is not used for more than 30 minutes, it automatically enters the stand-by mode. This saves money for you and valuable resources for the planet.



## **ATTENTION:**

Read the safety notes carefully before using this product.

PIC. 2

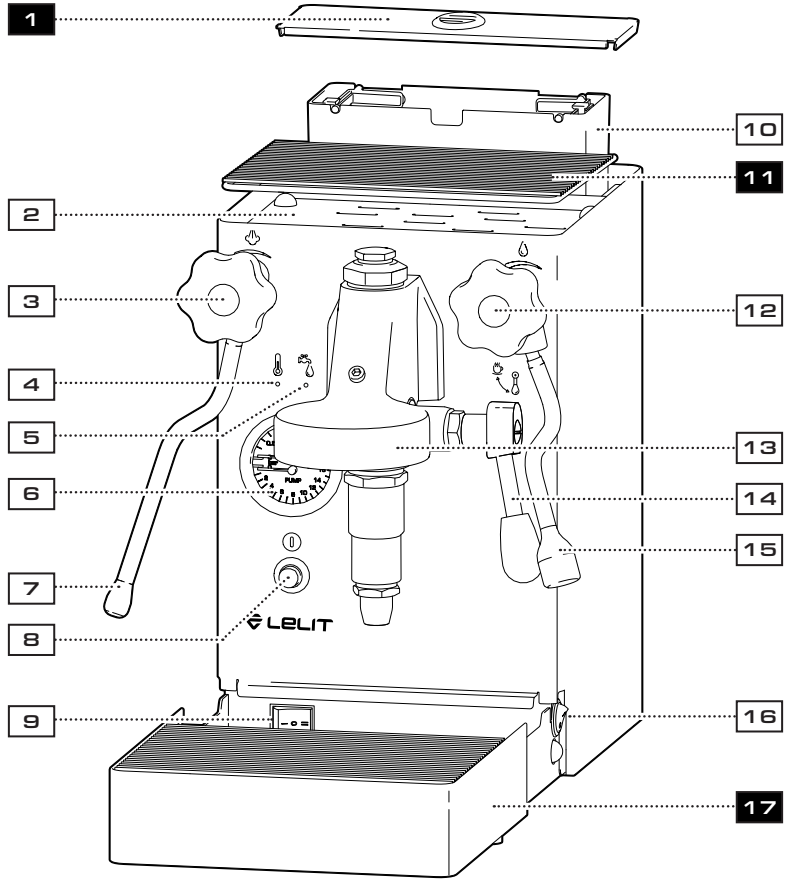

**1 11 17**

in the  
equipment box

## 2. Product overview

- |  |   |
|--|---|
| 1. Water tank cover  | 10. Water tank (2,6 l)                          |
| 2. Hot surface with grate for cups                         | 11. Grate for hot surface                       |
| 3. Steam dispensing knob                                   | 12. Hot water dispensing knob                   |
| 4. Machine ready pilot light                               | 13. Brewing group                               |
| 5. Full water tank pilot light                             | 14. Brewing group lever                         |
| 6. Manometer for steam and pump pressure during extraction | 15. Multi-directional, anti-burn hot water wand |
| 7. Multi-directional, anti-burn steam wand                 | 16. Xmode switch                                |
| 8. ON/OFF main switch                                      | 17. Removable drip tray, complete with grate    |
| 9. Temperature mode switch                                 |   |

## 3. Factory settings

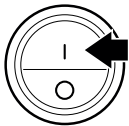

**Xmode (16)**  
Steam Xmode (pre-set value)

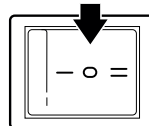

**Temperature mode (9)**  
Warm (pre-set value)



**Stand by:**  
ON



**Water softener filter:**  
Not inserted

MaraX has two functioning modes: these two switch modes aim to improve the thermal performance of the product. Each Xmodes can address different coffee workflows. **Read more about other functioning modes on Chapter 11.**

## 4. Equipment box

- A. 1 dose (9-11 g) coffee filter
- B. 2 doses PLUS (18-21 g) coffee filter
- C. Blind filter for backflushing
- D. Tamper in stainless steel with red wood handle (PLA481R)
- E. Raiser for espresso cups
- F. First cleaning kit (with 3 detergent powder single-dose bags and 1 single-dose bottle)
- G. Filterholder complete with 2 doses (14-18 g) coffee filter
- H. LELIT 35 l water filter
- I. Brush for group head cleaning
- J. Plastic spoon for coffee powder
- K. Power cord

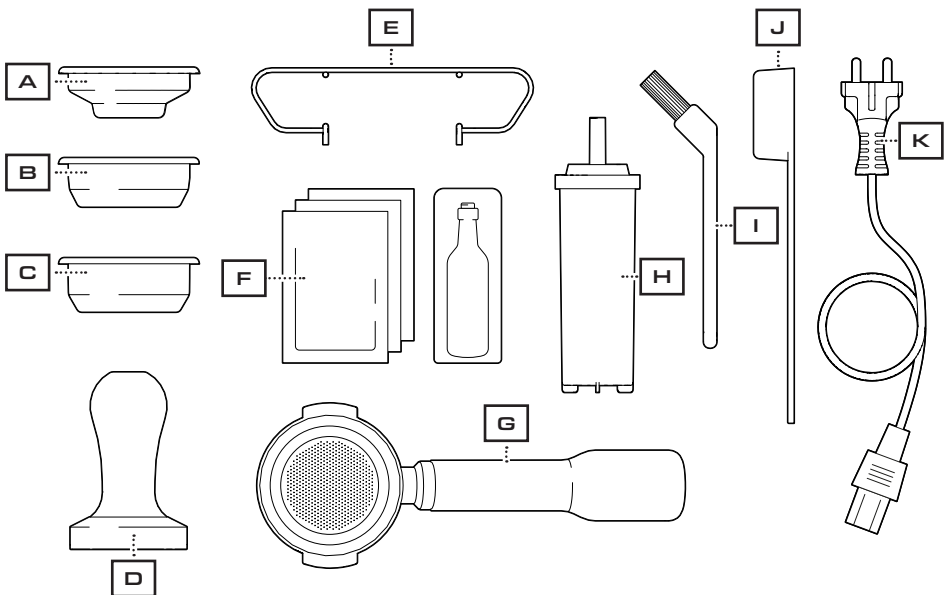

## 5. Packing

The packaging of your coffee machine has been studied and produced to be re-used. Save the box and all the packaging material for the entire warranty period and, if possible, even after.

Use the original box and all the packaging elements in case you need to send the machine back to your reseller or to an authorized service centre, for ordinary or extraordinary maintenance.

On our YouTube channel you will find a video on how to pack the machine properly, using the original box and packaging material.

Please also consult your LELIT reseller before shipping the machine away and follow his eventual specific instructions.

## 6. First start-up

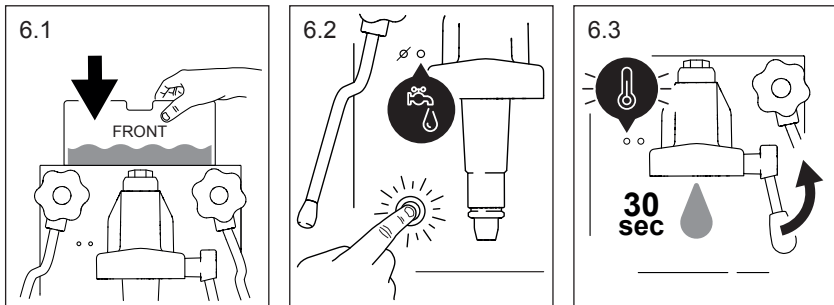

**⚠ Attention.** Remove the machine from its packing and follow the instructions printed on the box.

Place the machine on a solid, flat and dry surface and make sure the appliance is stable.

From the equipment box, take out the drip tray (17), the wire grid (11), the cover (1) and position them as indicated in Pic. 2.

**⚠ Attention.** Do not install the water filter, please run the first start-up and proceed with the water filter installation only afterwards.

Fill the water tank (10) with room temperature water up to the indicated maximum level and insert it in its seating (Pic 6.1). Use the power cord (K) to connect the machine to the electrical mains and turn ON the machine by pressing the ON/OFF (8) switch. If the water tank (10) is full of water and properly inserted in its seating, the pilot light (5) goes ON (Pic 6.2). The hydraulic circuit will need maximum 4 minutes from the 1st turn on to get filled with water. Once the

waiting time is over, the pilot light (4) will start flashing. Lift the group lever (14) completely (Pic 6.3). The brewing group (13) will start dispensing water (within 30 seconds). Let the water come out for about 30 seconds and then return the group lever to its initial position.

**Note.** *The lever installed on the group has two functioning positions: either fully lifted or fully lowered. There are not intermediate positions that guarantee an optimal performance during coffee brewing.*

**Attention.** *Please remember to fully lower the lever to avoid water leaking from the group.*

Now the hydraulic circuit is filled up. The machine will start heating the water to reach the pre-set values. This operation requires maximum 24 minutes: the pilot light (5) remains firmly on, while the pilot light (4) flashes.

The machine is ready for use when the 2 pilot lights (4, 5) and the lighted frame of the ON/OFF (8) switch are firmly on.

**Attention.** *During the heating phase, a small quantity of water will drain in the drip tray (17). This is normal and confirms the machine correct functioning (functions check).*

**Attention.** *MaraX has the drains into the drip tray. Check the drip tray, empty, and rinse it periodically!*

## 7. How to install the water softener filter

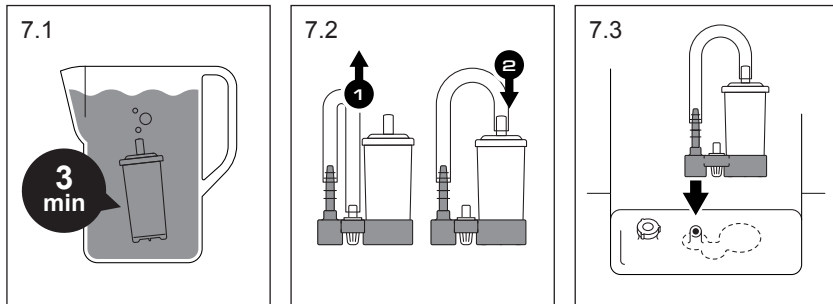

Before installing water softener filter (H) in the water tank (10), immerse the water softener filter in a jug full of water for about 3 minutes, to eliminate the air inside the filter that may cause a machine malfunction (Pic 7.1).

**Note.** The LELIT water softener filters are composed of sodium-based cationic resins. These filters placed inside the tank filter the water and capture the calcium and magnesium salts which would normally precipitate and form scale deposits in the espresso machine circuit. Once captured, these salts liberate sodium salts.

The LELIT water filters have a tested autonomy for 35 lt (PLA930S) and 70 lt (PLA930M): once reached this quantity of water and anyway within 4 months from the installation, the filter must be changed, because the cationic resin inside is worn out.

## 8. Espresso and coffee

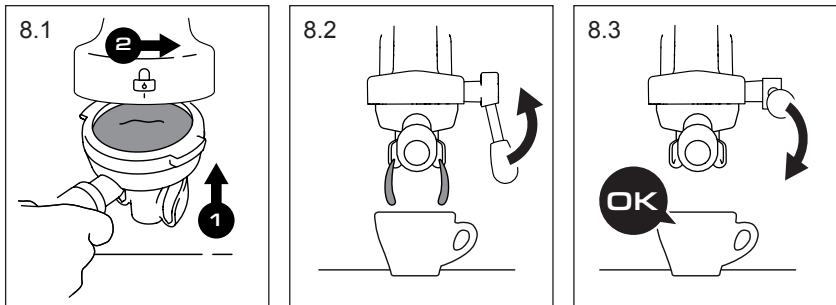

Choose your coffee filter, insert it into the filterholder (G) and fill it with the quantity of ground coffee suggested on the filter. Use the tamper (D) to press the coffee powder in the filterholder (G). Fix the filterholder (G) into the brewing group (13) and make sure the handle is aligned with padlock symbol present on the group (Pic 8.1).

**Note.** With a new machine, it is recommended to moisten the edge of the filter with some water to help reaching the correct position. After a short use, this position can be reached without effort.

Place the cup/s under the coffee slide and lift the group lever (14) to start the coffee extraction (Pic 8.2).

During the extraction phase, the lighted frame of the ON/OFF switch (8) flashes to indicate that the pump works. Return the group lever (14) to its initial position to stop the extraction (Pic 8.3).

**Attention.** Do not take any hot water during coffee brewing (when the lever is lifted).

Take out the filterholder (G) and empty the filter after every coffee extraction.

**Note.** During the normal functioning the pilot lights of the machine may flash or go off to indicate various states of the machine. See the chapter 14 “Pilot lights and states of the machine” for more details.

**Note.** We suggest you leave the filterholder (G) inserted into the brewing group (13) to help harmonize the temperature between the group and the portafilter complete of the filter.

**Attention.** Do not remove or loosen the filterholder (G) from the brewing group (13) during the coffee extraction to avoid burn risks caused by hot water leaks.

**Note.** A short purge cycle can be performed before each coffee extraction by lifting the lever completely for a few seconds. This procedure is not necessary as MaraX has an improved thermal stability, but it is suggested anyway.

## 9. Steam and hot water

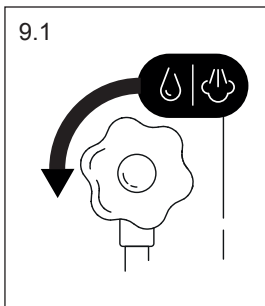

Open the steam dispensing knob (3) by turning it anticlockwise, with the steam wand pointed on the drip tray, to drain the small quantity of water. When the steam comes out close the knob. Place the milk jug (code PLA301S-M-L, not included), filled up to the beginning of the spout, under the steam wand and open again the steam knob (3) (Pic 9.1).

Once you have obtained the desired result, turn the knob (3) clockwise to stop the function. Let the steam out for few seconds to clean the tip.

Follow the same procedure for the hot water dispensing knob.

**Attention.** Do not take any hot water during coffee brewing (when the lever is lifted).

**Note.** The steam wand has a 2-holes tip, suitable for daily and normal usage. A 4-holes tip is available as spare, please contact your reseller for more details.

To activate the steam boost, lift the group lever (14) completely and return it to its initial position about 30 seconds before using the steam wand or the hot water.

**Read more about Steam Boost on Chapter 11.**

## 10. Stand-by mode EXTRA

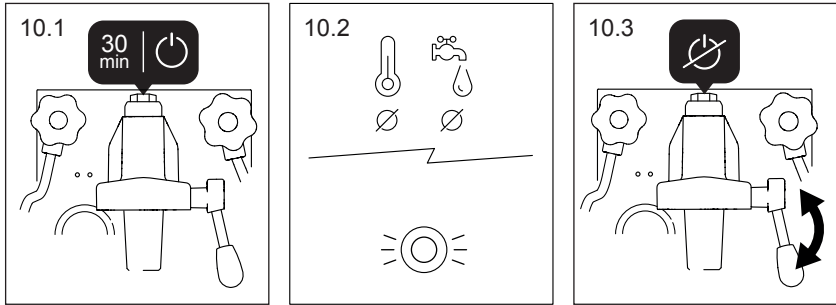

After 30 minutes of inactivity, the machine will go automatically in stand-by mode (Pic 10.1).

The lighted frame of the ON/OFF switch (8) flashes while the pilot lights (4 and 5) remain firmly off (Pic 10.2).

To re-start the machine, you must lift the group lever (14) completely and return it to its initial position (Pic 10.3).

Wait until all the pilot lights are firmly on before using the machine.

### **Disable or enable Standby function**

The Standby is normed by an EU directive for this type of coffee machine, but if you want, you can disable this function, below the procedure:

Turn off the machine (main switch 8).

Lift the coffee group lever (14).

Turn on the machine (main switch 8).

If the standby function is on, after 5 seconds the frame of the on/off switch (8) starts flashing (1on - 1off) and the status changes to “standby OFF”

If the standby function is off, after 5 seconds, all lights flash to confirm the switch to active standby.

Then switch off and on the machine to save the settings.

# 1 1. Functioning modes EXTRA

MaraX has 2 functioning modes: Xmode Steam that gives priority to Coffee and Xmode Coffee that gives priority to Steam.

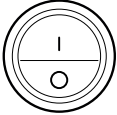

## Xmode switch (16)

You can choose the right Xmode for you and always get the best possible performance: press the 2-position switch (16) to change it. As per factory setting, you receive your MaraX on Xmode steam.

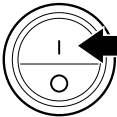

## On Xmode Steam (factory setting)

In this mode, the machine works to provide steam availability during the brewing process. In this scenario, the temperature profile of the brewing process is less stable and precise over the use of the product. Nonetheless, the machine has higher steam performances. The HX Boiler works more intensively to balance the thermal fluctuation inside the boiler during the brewing process.

The heating element is highly active:

- a. During coffee brewing to maintain stable the thermal brewing profile
- b. After coffee brewing to generate enough steam

*Best scenario of use: small office – flat white*

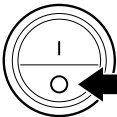

## On Xmode Coffee MaraX

In this Xmode, the software turns off the heating element during coffee brewing, on the one hand, reducing the risk of overheating (typical problem of HX machines) and on the other hand, increasing the thermal stability in the HX.

*Best scenario of use: specialty coffee (light – roasted coffee beans)*

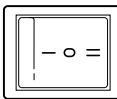

To recognise the setting the user is in, you just need to simply turn off and back on the machine; if the led of the power button blinks, this means that the Xmode coffee is active.



## Temperature mode switch (9)

Both Xmodes can run on specific temperature range. Press the 3-position switch (9) behind the drip tray to change the temperature range: I Hot (92°C) for a balanced, nutty and chocolatey cup (light-roast beans); 0 Warm (90°C) for a fruity, acidity and smooth cup (mid-roast beans) and II Extra hot (94°C) for a bitter and more intensive cup (dark-roast beans). On HX machines, the brew temperature highly depends on steam temperature, as they have only one boiler. In MaraX the two temperatures are quite independent from each other thanks to the double NTC system.

Please remember that these are suggestions

	 <b>Xmode Steam</b>	 <b>Xmode Coffee</b>
<b>Pilot light machine ready (4)</b>	It does not flash	It flashes till machine is ready
<b>Warmup</b>	In less than 24 minutes	
<b>During coffee brewing</b>	Heating element ON	Heating element OFF
<b>Steam boost</b>	More than 1.2 bar for 120s	

 **Note.** The warmup does not depend on which Xmode or temperature is selected. The warmup takes only 24 minutes.





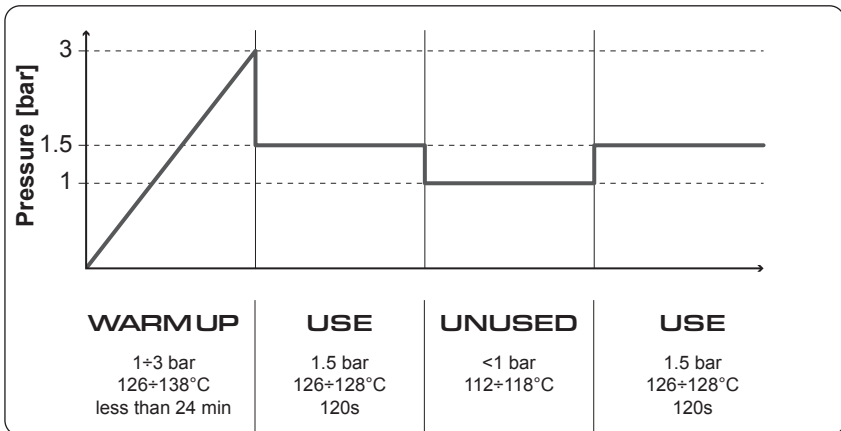

### Steam boost

Every time the lever is lifted and then lowered; the software tells the heating element to turn ON. This happens for two reasons: on the one hand, the boiler is heating up the cold water; on the other hand, the pressure to froth milk increases. This means that the user can even just warm up milk without brewing coffee, he just needs to lift and lower the lever to have more than 1.2 bar pressure for 120 seconds. The steam boost is active for 120 seconds because this duration allows the user to froth large quantities of milk and at the same time it reduces big temperature fluctuations that might influence the following coffees.

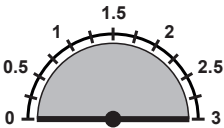

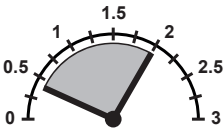
**⚠ Attention.** On Xmode Steam (factory setting) MaraX uses the temperature in the HX as reference point, therefore the steam pressure gauge may oscillate.

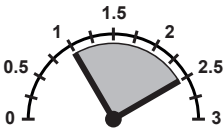
Below a table that indicates the pressure range based on usage:

WARM UP	TEMPERATURE KEEPING	COFFEE EXTRACTION
 <p data-bbox="240 550 308 598">0 - 3.2 bar</p> 	 <p data-bbox="520 550 588 598">0.4 - 2 bar</p> 	 <p data-bbox="800 550 868 598">1 - 2.5 bar</p> 

## 12. The art of espresso coffee EXTRA

Contrary to what you might think, making a perfect coffee is not that easy. It takes experience, ability, passion and a little bit of curiosity. In this paragraph we would like to share with you some of the basic rules for making a perfect cup of Italian Espresso.

16

### **Suggested doses:**

Ristretto (Strong) about 20 ml – Espresso about 30 ml – Lungo (Long) about 60 ml.

### **The “5 M’s”**

.....

If you want to make perfect Espressos, you should start by ensuring the five essential factors which turn a simple cup of coffee into an Espresso for connoisseurs! These are the “5 M’s”; in Italian: miscela (blend), macinatura (grinding), macchina (machine), manualità (skill) and manutenzione (maintenance).

#### **1 - Miscela (Blend)**

Good Espressos are always made with a good blend of coffee. An Espresso with the right taste requires a blend of two types of coffee, Arabica and Robusta. The first gives the coffee its delicate aroma and the right amount of acidity, while the second type gives it its full taste, body and cream. The quantities depend on your own taste. Try out different combinations until you find the blend you like the most!

#### **2 - Macinatura (Grinding)**

The grinder is a must for making good Espresso. Coffee should always be grounded just before it is used so that it preserves its taste and aroma. The LELIT grinders let you adjust the grinding level to suit the coffee blend to establish the correct extraction time and amount of cream.

#### **3 - Macchina da caffè (Coffee machine)**

LELIT machines are designed and built so that the water temperature can be adjusted to suit your needs. In addition, setting this variable correctly will allow you to extract from the ground coffee, not only the soluble substances that give it taste, but also the non-soluble ones that give body and flavour to your coffee.

#### **4 - Manualità (Skill)**

Half of the result depends on how you use the machine. A passionate expert is an essential part of the Espresso production chain and can enhance the result to bringing additional value to the final product. Therefore, passion and practice are the secrets to learn how to use the machine. You can experiment with different blends of coffee, grinding, pressing, water temperature and pressure, not just to make an Espresso, but to make the one that is right for you.

#### **5 - Manutenzione (Maintenance)**

Daily and scheduled maintenance and care of the machine will ensure the quality of the beverage and the durability of the product you have purchased. A clean machine says a lot about your passion for coffee making.

## Coffee varieties

.....

The choice of the blend is an essential factor for making the ideal coffee for your taste. There are a lot of different varieties of coffee blends on the market to choose from. The differences in flavour, aroma and texture depend on the quantities of the two varieties of coffee that make the blend.

### Arabica

This is a sweeter and more delicate variety of coffee, with a rich aroma and cream that is very thin, dense and compact.



#### Arabica

It is grown between 900/2000 m  
Rich aroma.

**Caffeine between 0.9 ~ 1.7%**

### Robusta

This variety is woody, bitter, fullbodied and spicy, with little aroma. Its cream is more frothier and greyer.



#### Robusta

It is grown between 200/600 m  
Spicy aroma.

**Caffeine between 1.8 ~ 4%**

No variety of coffee can make an ideal Espresso on its own. The perfect Espresso has a top layer of cream 2-3 mm thick, a colour that varies from nut brown to dark brown, with reddish tinges and light streaks, a harmonious flavour, a strong, balanced aroma and a sweet, long-lasting aftertaste. It has a strong aroma with notes of flowers,

fruits, toast and chocolate. These sensations can last just a moment or can persist for a few minutes in your mouth. The taste is round and well structured. The acid and bitter perceptions are well balanced whereas there is little or no astringency.

The ideal parameters to obtain this type of coffee are:

9 ± 0,5 g. of ground coffee.

25 seconds to brew 30 ml.

88/92°C when brewing and 80°C in the cup.

8/10 bar pressure during extraction.

Even Arabica blends often contain a small amount of Robusta, which is necessary to enhance the cream and add aroma and body to the espresso.

Blends made for coffee bars usually contain 20% Robusta but in southern Italy, where they prefer a stronger taste, the percentage can reach 40-50%.

At the end of the day, it's just a matter of taste... Experiment until you find the blend you like the most!

## Cappuccinos

.....

There's nothing better than a cappuccino to start your day. Although they are made and served everywhere, few people know how to make one properly.

Making the coffee is only part of this complex procedure. The froth often creates major problems, but thanks to the steam wand on our machine, with

a few suggestions and a little practice you'll soon be making cappuccinos just like in the coffee bars!

### Milk and jug

You need 100 ml of milk to make a cappuccino.

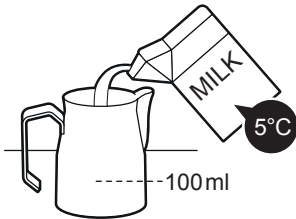

Fresh whole milk provides a smoother, creamier and tastier froth. Milk will not froth at over 65°C, so cold milk from the fridge should be used to allow more time for it to froth. The best jugs to use are made of stainless steel and have a spout, like the LELIT jug (code PLA301S – PLA301M – PLA301L – not included).

### Frothing the milk

Before using the steam wand, some steam should be released for about two seconds, as it always contains some water due to condensation.

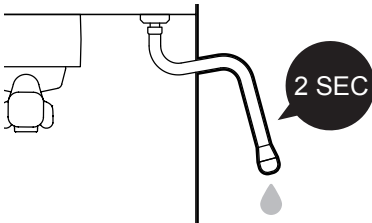

Insert the wand so that the end of the nozzle is near the side of the jug (pretend you have split the top section into four parts and insert the nozzle

into one of them) and about one centimeter below the surface of the milk. Since the milk will start to expand in volume, you will have to gradually lower the jug so that the nozzle is always kept immersed at the same depth. This process is complete when the milk reaches a temperature of about 37°C, or when you can feel the warmth with your hand. You can use the thermometer too (code PLA3800 - not included).

### Processing the milk

This phase is very important to make the cream thick, with a fine texture and a shiny surface.

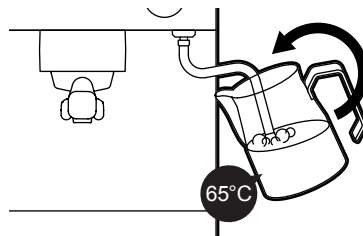

Insert the wand all the way down and tilt the jug to create a vortex. Heat the milk to the desired temperature, without exceeding 65°C. Close the steam knob, turning it clockwise. Prepare the milk by first tapping the jug on the countertop to remove any air bubbles and then rotating it to keep the milk and froth well amalgamated. The result should be a smooth, creamy surface without any bubbles.

### Pouring the milk

Please remember that steam boost is active regardless the Xmode the machine is set in. This means that once the coffee group lever (14) is lifted and

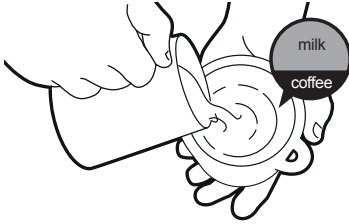

returned to its position, you have more than 1.2 bar at your disposal for 120 seconds. The optimal scenario is that you prepare your milk after making the coffee so that you have enough pressure to froth your milk like a real barista. Do not forget to clean the steam wand with a damp cloth and let some steam out to clean the tip.

## 13. Limescale prevention

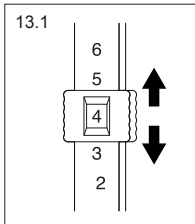

To prevent limescale deposits and grant a better result in the cup, use the water filter (H).

The filter found in the equipment box has an autonomy tested for 35 litres of water.

Use the slides put on the handles of the water tank (10) to remember the complete fillings of the tank and replace the water softener filter once exhausted (Pic 13.1).

**Note.** The water softener filter must be replaced every 14 complete fillings, or after 4 months of use. If the machine remains unused for 1 month, the water softener filter must be replaced with a new one.

**Note.** See chapter 6 “How to install the water softener filter” to replace the filter correctly.

**Note.** Please check the Chloride level of the water in the tank. The level should be lower than 30 ppm. If it is higher, please contact your reseller.

## 14. Daily cleaning

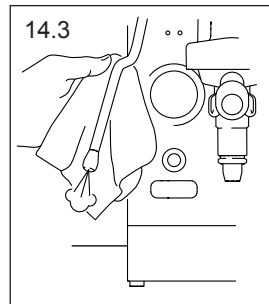
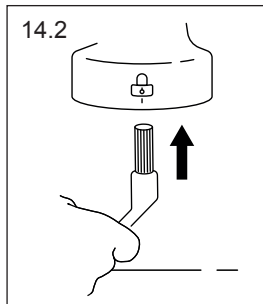
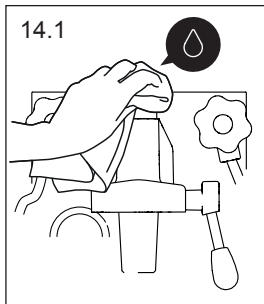

**Note.** For an optimal result we suggest you use our kit PLA9101 (not included) that contains a microfiber cloth with embroidered LELIT logo, a paintbrush with bristles in natural fibres and a brush with nylon bristles.

**General cleaning.** Use a soft cloth, preferably in microfiber, and moisten it with tap water to clean the stainless steel appliance body of the machine (Pic 14.1).

20 **Group cleaning.** After each extraction empty the coffee filter, wash the filterholder (G) and the relative filter with tap water and use the brush (I) to eliminate the coffee residues from the group gasket (Pic 14.2).

**Steam wand cleaning.** After frothing the milk, clean the nozzle of the steam wand (7) using a soft cloth and dispense a small quantity of steam to eliminate every possible milk rest in the holes (Pic 14.3).

## 15. Weekly cleaning

**Note.** In the equipment box you'll find the detergents (F) for the first cleaning cycle of the machine. Afterwards, we suggest you use our accessories PLA9201 and PLA9203 (not included).

**Filters and portafilter cleaning.** It's necessary to clean the filterholder to eliminate the coffee oils that may affect the taste of your drinks negatively. Place a jug under the hot water wand (15), turn the knob (12) anti-clockwise and take out about 1 l of water.

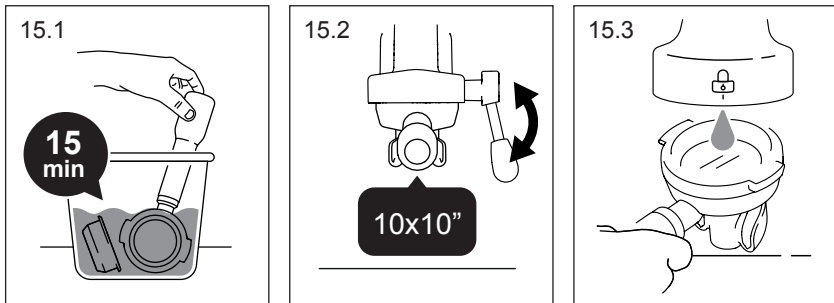

Insert the filterholder (G) and the used filters into the jug but pay attention not to immerse the filterholder handle (Pic. 15.1). Add 2 bags of detergent powder (F or PLA9201). After 15 minutes, empty the jug and rinse the filterholder (G) and the filters with plenty of tap water.

**Backflushing.** Insert the blind filter (C) into the filterholder and pour 1 bag of

detergent powder (F or PLA9201) into the filter. Insert the filterholder (G) in the group head (13) and lift the lever (14) for 10 seconds. Stop the function by lowering the lever completely and wait for 10 seconds. Repeat the procedure 10 times (Pic 15.2).

Remove the filterholder (G) from the group and rinse it with hot water from the brewing group (Pic 15.3).

Re-insert the filterholder (G) in the group head and repeat the previous operation 5 times for 10 seconds each time, without detergent powder.

Remove the filterholder (G) and take out the blind filter (C). Empty the drainage tray (17) and rinse the filterholder (G), the filters and the tray (17) with plenty of tap water.

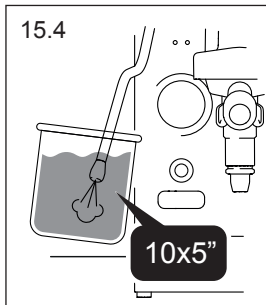

Steam wand cleaning. Fill a jug with 500 ml of cold water, add the content of 1 bottle of detergent liquid (F or PLA9203) and immerse the steam wand (7) in this solution.



Open the knob (3) and dispense steam for 5 seconds. Stop the function and wait for 5 seconds. Repeat the operation 10 times (Pic 15.4).

Repeat the entire procedure using 1 l of fresh water to rinse the steam wand (7) properly.

























## 16. Annual cleaning

The descaling of the hydraulic circuit of the machine must be done every year to ensure longevity and constant performances. This operation must be done by a specialized technician. You can see the centres authorized to run this procedure on our website: [LELIT.COM](http://LELIT.COM)

## 17. Pilot lights and states

		
Pilot light is on	Pilot light flashes	Pilot light is off

22

			State of the machine
			<b>Machine in heating phase</b> Wait until the machine is ready for use
			<b>Water tank is missing or water tank is empty</b> Fill the water tank (10) with water and insert it in its seating
			<b>Machine ready for use</b> You can start using the machine
			<b>Machine in Stand-by mode</b> Lift the group lever (14) completely and return it in its initial position to activate the machine. Wait until all the pilot lights are firmly on before using the machine.
			<b>Temperature sensor NTC1 disconnected or damaged</b> Contact the service centre
			<b>Temperature sensor NTC2 disconnected or damaged</b> Contact the service centre
			<b>Boiler filling phase has exceeded the maximum time</b> Check the correct position of the water tank (10) and remove eventual blockages. Re-start the machine with the main switch. If the problem persists, contact the service centre.

## 18. Most common problems **EXTRA**

### 1. The lighted frame of the main switch (8) flashes continuously

- a. Turn the machine OFF and ON and wait for the machine to get to the right temperature (24 min).
- b. The machine goes OFF.
- c. The Standby function is ON. Follow the instruction manual to learn how to disable the function (chapter 10).

### 2. The coffee is too cold

- a. The machine needs 24 minutes to get to the right brewing temperature: the pilot light (4) will remain ON after 24 minutes.
- b. Select a higher temperature range by switching the 3-position switch (9).
- c. Do not forget to warm up the cups before the extraction: keep the cups on the top surface of the machine.
- d. Insert the filterholder without coffee into the group, lift the group lever (14) and let some hot water come out of the group head. Proceed with the coffee extraction.

### 3. The coffee is dispensed too quickly and without cream

- a. Grind the coffee more finely or use a finer ground coffee.
- b. Increase the coffee quantity in the filterholder.
- c. Press the coffee more firmly.
- d. Change the coffee blend.
- e. If the above suggestions do not improve the result in the cup, test the machine with the blind filter: insert the blind filter into the filterholder, fix the filterholder into the group head and lift the group lever (14). If the pump manometer reaches 9 bar (or more) it means that the machine works correctly.

### 4. The coffee is not dispensed or is only dispensed in drops

- a. Grind the coffee more coarsely or use a coarser ground coffee.
- b. Reduce the coffee quantity in the filterholder.
- c. Press the coffee less.
- d. If the above suggestions do not improve the result in the cup, test the machine with the blind filter: insert the blind filter into the filterholder, fix the filterholder into the group head and lift the group lever (14). If the pump manometer reaches 9 bar (or more) it means that the machine works correctly.

e. Run a backflushing procedure to clean the essential parts of your coffee machine, see the chapter 15.

#### **5. The coffee cream is not thick**

- a. Following the steps of a correct coffee extraction, try to select a higher temperature range by pressing the 3-position switch (9).
- b. Select a suitable coffee blend knowing that a thick cream needs a good percentage of Robusta: read more about this in chapter 12.

#### **6. The hot water wand leaks**

- a. Follow the instructions below:
  1. Turn ON the machine and wait until the steam manometer indicates the pressure. Place a jug under the leaking wand and turn OFF the machine. Take care to avoid contact with water sprays.
  2. Open the water knob and let the hot water come out completely.
  3. Close the tap and turn ON the machine.
  4. Check the water wand: if the leaking persists, run a descaling procedure (contact your reseller for more details this regards).
  5. If the leaking still persists, contact your reseller to have the machine checked and repaired.

#### **7. No steam from the steam wand**

- a. Follow the instructions below:
  1. Check the pressure indicated on the steam pressure manometer: if there is no pressure, turn the machine OFF and ON and wait 10 minutes.
  - 2a. If the manometer registrates no pressure, contact your reseller for check and repair.
  - 2b. If the manometer registrates pressure, remove the wand tip and release some steam without the tip: if the steam comes out regularly, it means that the tip is blocked. Close the steam tap and clean the tip properly: make sure the holes are free.
  3. Reassemble the tip on the steam wand.

#### **8. No hot water from the water wand**

- a. Follow the instructions below:
  1. Check the pressure indicated on the steam pressure manometer: if there is no pressure turn the machine OFF and ON and wait 10 minutes.
  - 2a. If the manometer registrates no pressure, contact your reseller for check and repair.
  - 2b. If the manometer registrates pressure, remove the water aerator and release some hot water without the aerator: if the water comes out regularly, it means that the aerator is blocked. Close the water tap and clean the aerator properly.
  3. Reassemble the part on the water wand.

**9. The group head is just warm**

a. Follow the instructions below:

1. Turn the machine OFF and ON and let some water come out from the group head.
2. Wait 24 min to check the steam manometer.
3. If the manometer shows 0, check the water level in the water tank and the correct position of the water tank inside the machine.

4a. If the manometer shows a pressure increase, press the 3-position switch (9) to select the position II. Let hot water come out from the group head (about 1 cup) and wait 24 min until the machine reaches the right temperature to brew coffee.

4b. If the manometer shows no pressure increase, contact your reseller for check and repair.

**10. The machine does not heat, and the pressure does not increase**

a. Follow the instructions below:

1. Check the power cord and make sure it is correctly inserted into the socket.
2. Check the water level in the water tank.
3. Check the correct position of the water tank.
4. Check the “water presence” pilot light (5): it has to be firmly ON.
5. Turn the machine OFF and ON.
6. If after 10 min the manometer registers no pressure, contact your reseller for check and repair.

**11. The drip tray fills up too quickly**

a. All the drainage tubes from the boiler end up into the drip tray, therefore check the drip tray and empty it periodically.

**12. After the backflushing the group lever (14) makes a strange noise and is hard to handle**

a. The backflushing procedure may remove the lubricants and the coffee oils. This does not affect the machine functioning but may cause a strange noise of the lever during handling.

b. The lever mechanism is lubricated by the oils released during the coffee extraction; therefore, the lever will get lubricated again after 10/20 coffee extractions and the strange noise will disappear.

c. For more details regarding the lubrication of the entire group mechanism and the suitable product to use for this procedure, please contact your reseller.

## 19. Warranty terms

### LEGAL WARRANTY

.....

26

This product is covered by the warranty laws valid in the country where the product has been sold; specific information about the warranty terms can be given by the seller or by the importer in the country where the product has been purchased. The seller or importer is completely responsible for the product.

The importer is completely responsible also for the fulfilment of the laws in force in the country where the importer distributes the product, including the correct disposal of the product at the end of its working life.

Inside the European countries the laws in force are the national laws implementing the EC Directive 44/99/CE.



### IMPORTANT INFORMATION

*For the correct disposal of the product in accordance with EU DIRECTIVE 2002/96/EC and with Legislative Decree no. 151 of 25 July 2005. At the end of its working life, the product must not be disposed of as urban waste. It must be taken to a special authorised differential waste collection centre or to a dealer providing this service. Disposing of a household appliance separately avoids possible negative consequences for the environment and health caused by improper disposal and enables recovery of the materials it contains, with significant savings in energy and resources. The product is marked with a crossed-out wheellie bin as a reminder of the need to dispose of household appliances separately.*

27



### EC DECLARATION OF CONFORMITY

*Gemme Italian Producers srl declares under its own responsibility that the product:*

*Coffee machine type: PL62X*

*to which this declaration relates conforms to the following standards:*

*EN 60335/1 - EN 60335/2/15 - EN 61000/3/2 - EN 55014*

*pursuant to directives:*

*2014/35/EU - 2014/30/EU*

*NB: This declaration is null and void should the machine be modified without our specific authorisation.*

*Castegnato, 20/02/2020 - Managing Director*

**Gemme Italian Producers srl**  
**25045 Castegnato (Bs)**



LELIT.COM



7800052 REV 01

©2020 Gemme Italian Producers Srl.  
All Rights Reserved